



Mormugao Port Trust, GOA

Serving The Nation Since 1885

AN ISO 9001:2000, ISPS COMPLIANT PORT

MORMUGAO PORT TRUST
MECHANICAL ENGINEERING DEPARTMENT

CME/XEN (E)/HL/W-2/2016

Mormugao Port Trust intends to invite Budgetory Offer from Contractors who have Supplied, Installed, Tested and Commissioned(SITC) of Diesel Generator of capacities 300 KVA and above with acoustic enclosure and its controls. The Budgetory Offer documents containing the details of technical specifications and Terms & Conditions can be downloaded from the Mormugao Port Trust website www.mptgoa.com. Copies of Budgetory Offer documents are also available in **Executive Engineer(E-HL)**'s Office at Administrative Office Bldg., Mormugao Port Trust, Sada, Vasco-Goa during all working days.

The completed Budgetory Offer should be submitted with supporting documents on or before 20.05.2016.

CHIEF MECHANICAL ENGINEER
MORMUGAO PORT TRUST



Mormugao Port Trust, GOA

Serving The Nation Since 1885

AN ISO 9001:2000, ISPS COMPLIANT PORT

BUDGETORY OFFER FOR PROVIDING 750 KVA GENERATOR WITH ACOUSTIC ENCLOSURE AND AMF PANEL AT PORT ADMINISTRATIVE BUILDING AT HEADLAND-SADA-GOA

1.0 INTRODUCTION

The Mormugao Port Trust has a 3.3KV/415 V, 1.1MW substation at the basement of the Ports administrative building at Headland Sada which caters to the electrical loads of the admin building and around the vicinity. There is a 500 KVA Generator without acoustic enclosure, Caterpillar make, housed in the Administrative building itself to offer back up power in case of power failures. This Generator has been installed in the year 1997 and has been in use ever since for the last 16 years. This Generator needs to be replaced with a 750 KVA Generator with acoustic enclosure and control panel to meet present and future demands.

2.0 SCOPE OF WORK INCLUDES:

(a) The Scope of work involves Supply, Installation, Testing and Commissioning of 750 KVA Generator with acoustic enclosure and control panel. Subsequent to the submission of Budgetory offer with supporting documents and the budgetary quote, an open tender will be published on the Port website to carry out the work

The overall scope of work includes:-

- i) Dismantling of the existing 500KVA Generator Sr. No. 5AGVO691Caterpillar make Stamford Alternator procured from GMMCO and AMF panel with Controller, C&S Make Model EC-2 and 2 Nos of Schneider make 1000A ACBs, Model no. Masterpact MV10HI and consider the same in buyback option except the 2 Nos of Schneider make 1000A ACBs.
- ii) Before dismantling of the existing generator, a 500 KVA generator has to be hired by the Bidder and it has to be connected to the existing distribution panel to provide uninterrupted power during the time of commissioning the new generator.
- ii) After dismantling the existing 500KVA generator, foundation has to be made for new 750KVA generator in the same room, which is of size 7.8mtr width, 7.7 mtr length and 3.7mtr height .The existing room length of 7.7 mtr will be extended by the port by another 2 mtr to provide adequate space for movement around generator .The Generator control panel shall be integrated with the existing 500/630 KVA Bus Coupler panel thereafter intermediate panel located 10 mtr. away. The drawing of the existing Bus Coupler Panel is at **Annexure-1**.
- iii) Supply of 750 KVA Generator of make Powerica Model:KTA 38-610 with acoustic enclosure, with control panel having ACB of 1250 Amps with suitable batteries and battery charger. The engine make shall be Cummins Alternator shall be Stamford make..
- iv) Supply and installation of intermediate panel interconnecting existing Bus Coupler Panel and Generator control panel. The intermediate panel shall house the two 1000 Amps ACB's, Schneider Model No. Masterpact MV10H1 that will be supplied by the Port from the existing AMF panel of 500 KVA

Generator. It shall also house a Deep sea Electronics Model DSE 334 Controller.

v) Supply, Laying, Testing and Commissioning of one run of 4c x 1000 mm² XLPE Cable will have to be laid from Generator control panel to the intermediate panel and Bus Coupler panel. The drawings for the proposed Generator integration with the existing Bus Coupler panel and the logic required is at **Annexure-2**.

vi) The emission of the 750 KVA Generator shall be connected to the existing emission stack of height 20 mts. to clear the height of the Administrative Building. The diameter of the existing emission stack at the point of interconnection is 71cms.

vii) Installation, Testing and Commissioning of the 750 KVA Generator with acoustic enclosure, control panel with suitable batteries, battery charger, etc as a system. Necessary clearances /permissions/approvals from RIO/Competent Authorities shall be taken by the Contractor. All test reports/records/measurements shall form part of commissioning procedure.

- The technical details and their quantities required are mentioned in technical specifications followed by the Bill Of Quantity(BOQ).

3.0 Terms and Conditions:

i) The firms shall submit their budgetary offer along with all technical details. The work shall be contracted out through an open tender under two cover system within 2-3 weeks of receipt of the budgetary offers.

ii) The budgetary offers of the bidder shall remain valid for a period of **THREE MONTHS** from the date of opening of the budgetary offer.

iii) **COMMENCEMENT AND COMPLETION OF WORK:**

The successful bidder shall commence the work within 10 days from the date of placement of order .

The Schedule of work is as follows:

- a) Dismantling of existing generator - 3 days,
- b) Foundation/curing and cabling - 5 days
- c) Installation of Generator and Intermediate panel – 4days
- d) Cable Termination, Testing & Commissioning – 3 days

Therefore, the standby 500 KVA Generator shall be hired for 15 days during the time of commissioning.

iv) **GUARANTEE:**

The work shall be guaranteed for a period of twelve months from the date of satisfactory completion and handing over. All the defects/deficiencies noticed during the guarantee period will be rectified by the Contractor, free of cost by way of repairs or replacement as found necessary by the Engineer. The decision of the Engineer in respect of the above will be final and binding on the Contractor.

4.0 BUDGETORY OFFER DOCUMENT

The firms are expected to examine the terms and conditions and technical specifications in the Budgetory offer document.

5.0 BUDGETORY OFFER SUBMISSION

i) The Budgetory Offer shall be submitted on or before 20.05.2016 **by 3.00 p.m** along with technical details with terms and conditions. The document may be sent either by hand or post or by e-mail.

ii) The Budgetory offer shall be addressed to the following address:

Executive Engineer(E-HL),
Mechanical Engineering Department,
Mormugao Port Trust,
Electrical Section, 1st Floor,
Admin. Building, Goa - 403804
Phone : (0832) 2594241
Fax : (0832) 2521175
Email : xene.mgpt@gmail.com

6.0 TECHNICAL SPECIFICATIONS

Generator

Supply of 600KW/750KVA SILENT Diesel Generator make Powerica, Model: KTA 38-610 with CPCB-II approved acoustic enclosure with 1250 Amps ACB of make Schneider/ABB/Siemens

1) Diesel Engine specifications:

a) Make: Cummins, Model:KTA38 G13, Radiator cooled, 987 BHP at 1500 RPM, Well designed air handling unit with

- Dry type, Heavy duty, Replaceable paper element air cleaner with restriction indicator
- Outboard aftercooling with 2 pump 2 loop system
- Optimised turbocharger for increased altitude capabilities

b) Starting system:

- Electrical start motor with soft start engagement feature 24 volt Dc electrical
- Battery charging alternator
- 2 nos 12 volt DC lead acid maintenance free batteries

2) Alternator specifications:

Make: Stamford, Rated:600KW/750KVA, 415V

Brushless type, Screen protected, Revolving field, Self excited alternator, class H insulation

The Generator control panel consists of the following parts:

- Indicating LED lamps for 'Load ON' and 'Set Running'
- Instrument fuses duly wired and ferruled
- Air Circuit Breaker (ACB) of 1250amps rating with overload and short circuit protections
- Engine Metering: Oil pressure, High/Low coolant temperature, Low coolant level, Oil temperature, Intake manifold temperature, Battery voltage, Engine speed
- AC Alternator Metering: Line-Line Voltage and Line-Neutral Voltage, phase Current,kW, kVAR, Power factor, kVA, and Frequency.
- Engine Protection: Low lube oil pressure, High/Low coolant temperature, Over speed, Battery Over/Under/Weak Volts, Fail to crank/start, Cranking lockout, Low fuel level, Sensor failure.
- AC Alternator Protection: Protective relays for short circuit, Over/Under voltage, Over/Under frequency, Over current, Overload, Reverse power.

Mounting arrangement

- Engine and alternator are mounted on a common MS fabricated base frame with AVM pad

ACCESSORIES

The following accessories shall be supplied: -

- i) Fuel oil day tank (990 Litres capacity) with outlet valve fuel level Indicator, drain valve and hand hole for cleaning.
- iii) Hospital grade silencer suitably optimized to meet stringent noise emission standard laid down by MoEF/CPCB-II

Controller

Controller specifications:

- i) Make of controller:Deep Sea Electronic Controller Model: DSE 334.

Panel :

The Intermediate Panel and generator control panel shall be fabricated from CRCA sheet steel and 2 mm thick, Powder coated finish. The panel manufacturer shall submit CPRI/ERDA Type test certificates. The intermediate panel shall house two nos 1000 Amps ACBs that will be dismantled from the existing AMF panel of 500 KVA Generator and the Deep Sea Electronic Controller with control cabling from Generator panel to intermediate panel.

Bill Of Quantities(BOQ) for providing 750 KVA Generator with Acoustic Enclosure and Control Panel at Port Administrative Building at Headland-Sada.

Sr. No.	Description of work	Unit	Qty.	Rate/Unit (Rs.)		Amount (Rs.)
				In figure	In words	
1	Connecting exhaust of Generator to stack for the Generator set up and painting with the help of M.S piping and accessories of matching dimensions as per RIO/prevaling statutory regulations..	LS	LS			
2	Supply of 750 KVA Generator as per technical specifications	LS	LS			
3	Supply, installation, testing and commissioning of Intermediate Panel as per technical specification to house : 1) Two nos 1000 Amps ACBs that will be dismantled from the existing AMF panel of 500 KVA Generator. 2) Electronic Controller with control cabling from Generator panel to intermediate panel.	LS	LS			
4	Supply, laying, testing and commissioning of the 4c x 1000 sq. mm XLPE Cables from Generator control panel to Intermediate panel and existing Bus Coupler with lugged terminations	Mtr.	15			
5	Provision of earthing for the Generator with copper plate 'pipe in pipe' technology and connecting by of 25mm x 3 mm thick G.I. strips	Nos.	4			
6	Installation, Testing & Commissioning of 750 KVA Generator as per logic system specified.	LS	LS			
7	Dismantling of existing 500 KVA Generator AMF panel, Battery charger, batteries, etc from existing Generator room & thereafter considering the above items in buyback option except the two 1000 Amps Schneider make ACBs of the AMF panel which shall be utilized in the Intermediate panel.	LS	LS			(-)

8	Hiring of 500KVA diesel generator	Days	15			
Total Amount						

(Rupees _____ only)

SINGLE LINE DIAGRAM OF A.O. BLDG.

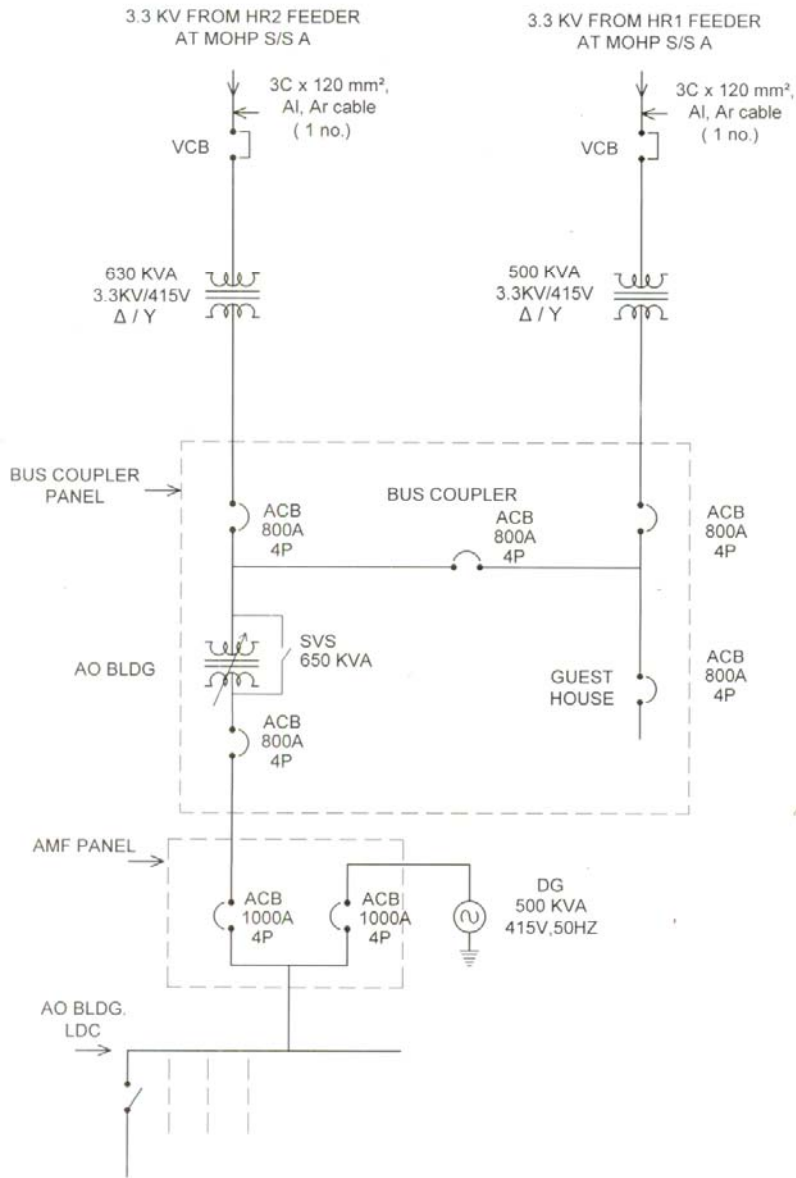

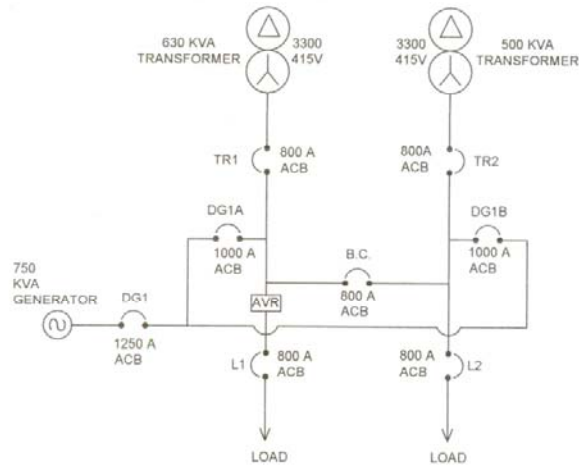

STAGES	DG1	TR1	DG1A	B.C.	TR2	DG1B	L1	L2
1	OFF	ON	OFF	OFF	ON	OFF	ON	ON
2	ON	OFF	ON	OFF	ON	OFF	ON	ON
3	ON	ON	OFF	OFF	OFF	ON	ON	ON
4	ON	OFF	ON	OFF	OFF	ON	ON	ON
5	OFF	ON	OFF	ON	OFF	OFF	ON	ON
6	OFF	OFF	OFF	ON	ON	OFF	ON	ON

NOTE : DG1A & DG1B ACB'S TO BE USED FROM EXISTING 500KVA AMF PANEL WITH DSE 334 CONTROLLER.